

After recording return to:
Michael Graham, Land Administrator
Fulton County Land Division
141 Pryor Street, SW, Suite 8021
Atlanta, GA 30303

Cross Reference

Deed/Plat Book 65382, Page 192
Deed Book 67296, Page 205

INDEMNIFICATION, MAINTENANCE AND LAND USE AGREEMENT FOR PRIVATE IMPROVEMENT

THIS AGREEMENT made this 17th day of Nov 2023, between **MILTON LAND INVEST, INC.** a property owner within Fulton County, Georgia, his successors, affiliates and assigns, as Indemnitor ("Owner"), and **FULTON COUNTY, GEORGIA**, a political subdivision of the State of Georgia ("County").

For good and valuable consideration, receipt of which is hereby acknowledged, it is hereby agreed as follows:

1.

Owner warrants that he is the full and true owner and has clear title to that certain property known as **HEATHERTON located at 1240 Mayfield Road, Milton, GA. 30009** and as more fully described in that certain conveyance recorded in Deed Book 65382, Page 192 of Fulton County, Georgia records, on which Owner desires to install certain private improvements (the "Private Improvements") as more fully described in Exhibit "A", attached hereto and incorporated herein by reference.

2.

Previously, Fulton County was granted a water meter easement, as referenced in and recorded at Deed Book 67296, Page 205 of Fulton County, Georgia records, and hereby grants Owner a License to enter within portions of its water meter easement, to construct, repair and replace, from time to time as may be needed, certain private improvements at his sole cost and responsibility, said private improvements as the same are more fully described in Exhibit "A" (the "Private Improvements").

3.

With respect to this License, Owner shall install and construct the Private Improvements in a good and workmanlike manner and in compliance with all state, local, and Fulton County laws and regulations, including but not limited to, all current state, local and Fulton County laws and regulations governing soil erosion and sedimentation control. Owner will at all times adhere to best management

practice procedures to protect the environment in connection with the construction, repair and/or maintenance of the Private Improvements.

4.

This License shall commence on the date of execution hereof and shall continue in full force and effect unless and until it is terminated at the will of the County.

5.

Owner may terminate this License and Agreement by written notice to the County and shall remove the Private Improvement at his sole costs and return the area to its natural vegetative state. If during the term of this License, the area containing the Private Improvements is condemned by the County or its assign, Owner shall make no claim in the condemnation proceedings for compensation for the Private Improvements.

6.

Fulton County personnel and/or agents shall have free access to and across the Private Improvements to perform routine maintenance and any emergency repairs to the existing public improvements.

7.

Owner shall be solely responsible for the maintenance, repair and replacement of the Private Improvements and the County grants Owner a right of access in order to carry out these obligations.

8.

Notwithstanding any other provisions, in the case of an emergency, Fulton County may immediately suspend or revoke the License without notice in order to protect the health, safety, and welfare of the public. In non-emergency situations, after providing at least 10 days' notice to Owner, Fulton County may suspend or revoke the License in order to carry out any necessary governmental function. In the event of the suspension or revocation of the License, Owner must cure all defects specified by the County in its notice and within the time reasonably specified by the County. Failure on the part of Owner to cure any defects within the allotted time will be grounds for the County to terminate the License. Alternately, the County may, but shall not be required to, cure any such defect at the sole cost and expense of Owner. The County may elect to terminate the License at will and remove the Private Improvements without liability for loss or damage for such removal. Fulton County shall remove the Private Improvements so as not to damage other portions of Owner's property and is granted a right of entry by Owner on the other portions of Owner's property to effectuate the repair, if necessary.

9.

Owner hereby agrees to indemnify Fulton County and hold Fulton County harmless from any and all damages which Fulton County may suffer and from any and all liability, claims, penalties, forfeitures, suits, and costs and expenses incident to the granting of the License and this Agreement (including cost of defense, settlement, and reasonable attorney's fees), which it may hereafter incur, become responsible for, or pay out as a result of the death or bodily injuries to any person, destruction or damage to any property, contamination of or adverse effects on the environment, or any violations of governmental laws, regulations, or orders caused, in whole or in part, by the negligent act, negligent omission or willful misconduct of Owner, his employees, subcontractors, or assigns in the performance of this License or Agreement.

10.

Owner agrees to repair or replace in a manner acceptable to the County and/or the owner thereof any public utilities damaged by its employees or subcontractors during performance of this License and Agreement or resulting from the failure of the Private Improvements. At its election the County may repair or replace the damaged utility and assess all costs against Owner.

11.

The License conveyed to Owner by this Agreement shall be binding upon Owner, his assigns, affiliates, and successors. This Agreement shall be governed by and construed in accordance with the laws of the State of Georgia. If any provisions of this Agreement is held to be unenforceable for any reason, the unenforceability thereof shall not affect the remainder of the Agreement, which shall remain in full force and effect, and enforceable in accordance with its terms.

12.

The License conveyed to Owner by this Agreement shall constitute a covenant running with the land and shall be recorded in the real property records of Fulton County, Georgia and shall be binding upon all subsequent transferees of said property.

13.

All notices, consents, request, demands or other communications to or upon the respective party shall be in writing and shall be effective for all purposes upon receipt, including, but not limited to, in the case of (i) personal delivery; (ii) delivery by messenger, express or air courier or similar courier; or (iii) delivery by United States first class certified or registered mail, postage prepaid and addressed as follows:

COUNTY: Fulton County
Director of Public Works
141 Pryor Street, SW, 6th. Floor
Atlanta, GA. 30303

with a copy to: County Attorney
Office of the County Attorney
141 Pryor Street, SW, Suite 4038
Atlanta, GA. 30303

OWNER: Milton Land Invest, Inc.
4080 McGinnis Ferry Road, Suite 704
Alpharetta, GA 30005

Re: 2nd District , 2nd Section, Land Lots 1030, 1059 & 1102

Parcel Number: 22 431010590330

IN WITNESS WHEREOF, the parties have executed this Agreement at Atlanta, Georgia, as of the day and year first above written.

Signatures:

OWNER: MILTON LAND INVEST, INC.

Signed sealed and delivered in the presence of

[Signature]
Unofficial Witness
[Signature]
Notary Public
My Commission Expires: 3/9/2026

[Signature]
Signature (Authorized Party to Bind Owner Entity)
Thomas E. Sharp, President
Signatory's Name and Title (printed)

(Notary Seal)
(Notary Stamp) 

Owner's Address:
4080 McGinnis Ferry Road
Suite 704
Alpharetta, GA. 30005

Attest: 
[Signature]
Clerk of Commission

FULTON COUNTY, GEORGIA
By: [Signature]
Chairman, Board of Commissioners

APPROVED AS TO CONTENT:
[Signature]
David E. Clark, Director
Department of Public Works

APPROVED AS TO FORM:
[Signature]
Y. Soo Jo, County Attorney

ITEM # 24-0031 RCS 1/24/24
REGRESS MEETING

EXHIBIT "A" - LEGAL DESCRIPTION

Heatherton Subdivision

All that tract or parcel of land lying and being in Land Lots 1030, 1059 and 1102 of the 2nd District, 2nd Section, in the City of Milton, Fulton County, Georgia, and being more particularly described as follows:

COMMENCING at an iron pin found (#4rebar) located at the intersection of the northeasterly right-of-way of Mayfield Road (right-of-way varies) and the easterly line of Land Lot 1102 which is the common line between Land Lot 1102 and 1103 of the said 2nd District; having thus established the **TRUE POINT OF BEGINNING** leaving said point and running $N80^{\circ}12'22''W$ along the said northeasterly right-of-way of Mayfield Road for a distance of 940.66 feet to a point; thence running $N09^{\circ}55'57''E$ along the said northeasterly right-of-way of Mayfield Road for a distance of 9.49 feet to a point; thence running $N80^{\circ}04'03''W$ along the northeasterly right-of-way of Mayfield Road for a distance of 334.42 feet to a point; thence running $N09^{\circ}55'57''E$ along the northeasterly right-of-way of Mayfield Road for a distance of 31.43 feet to a point located on the southeasterly side of an old abandoned road (formerly known as Old Bethany Road); thence leaving said right-of-way and running $N55^{\circ}35'38''E$ along the southeasterly side of said old abandoned road for a distance of 124.29 feet to a point; thence running in a northeasterly direction along the southwesterly side of said old abandoned road and following the curvature thereof along a curve to the left for an arc length of 207.17 feet (said arc having a radius of 997.69 feet and being subtended by a chord of $N50^{\circ}36'28''E$ – 206.80 feet) to a point located at the end of said old abandoned road: thence running $N48^{\circ}30'06''W$ for a distance of 18.68 feet to a point; thence running $N41^{\circ}22'19''E$ for a distance of 275.43 feet to a point; thence running $N05^{\circ}14'51''W$ for a distance of 100.49

feet to a point; thence running $N05^{\circ}44'33''W$ for a distance of 691.65 feet to a point located on the north line of Land Lot 1059 which is the common line between Land Lot 1059 and 1030; thence running $N89^{\circ}56'51''E$ along said Land Lot Line for a distance of 462.20 feet to a point; thence leaving said Land Lot Line and running $N33^{\circ}55'35''E$ for a distance of 201.56 feet to a point; thence running $N33^{\circ}37'31''E$ for a distance of 181.42 feet to a point; thence running $N34^{\circ}01'49''E$ for a distance of 180.62 feet to a point; thence running $N34^{\circ}00'58''E$ for a distance of 283.80 feet to a point located on the east line of Land Lot 1030 which is the common line between Land Lot 1030 and 1031; thence running $S00^{\circ}00'57''W$ along said east line of Land Lot 1030 for a distance of 427.28 feet to a point; thence running $S00^{\circ}50'16''W$ along the said common line of Land Lot 1030 and 1031 and the east line of Land Lot 1059 which is the common line between Land Lot 1059 and 1058 for a distance of 882.16 feet to a point; thence running $S00^{\circ}50'08''W$ along the said east line of Land Lot 1059 for a distance of 265.24 feet to a point; thence running $S02^{\circ}00'15''W$ along the said east line of Land Lot 1059 and the east line of Land Lot 1102 for a distance of 595.81 feet to an iron pin (#4 rebar) which is the **TRUE POINT OF BEGINNING**. Said tract contains 33.99 acres.

EASEMENT ENCHROACHMENT AREA:
 0.039 ACRES
 1,680 SQ.FT.

LINE TABLE		
LINE	DISTANCE	DIRECTION
L1	84.01'	N81°05'56"W
L2	20.00'	N09°47'38"E
L3	84.01'	S81°05'56"E
L4	20.00'	S09°47'38"W

HEATHERTON WAY
 (PRIVATE)

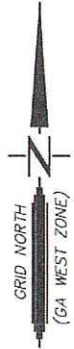

LL
 1059

APPROX. LAND LOT LINE

LL
 1102

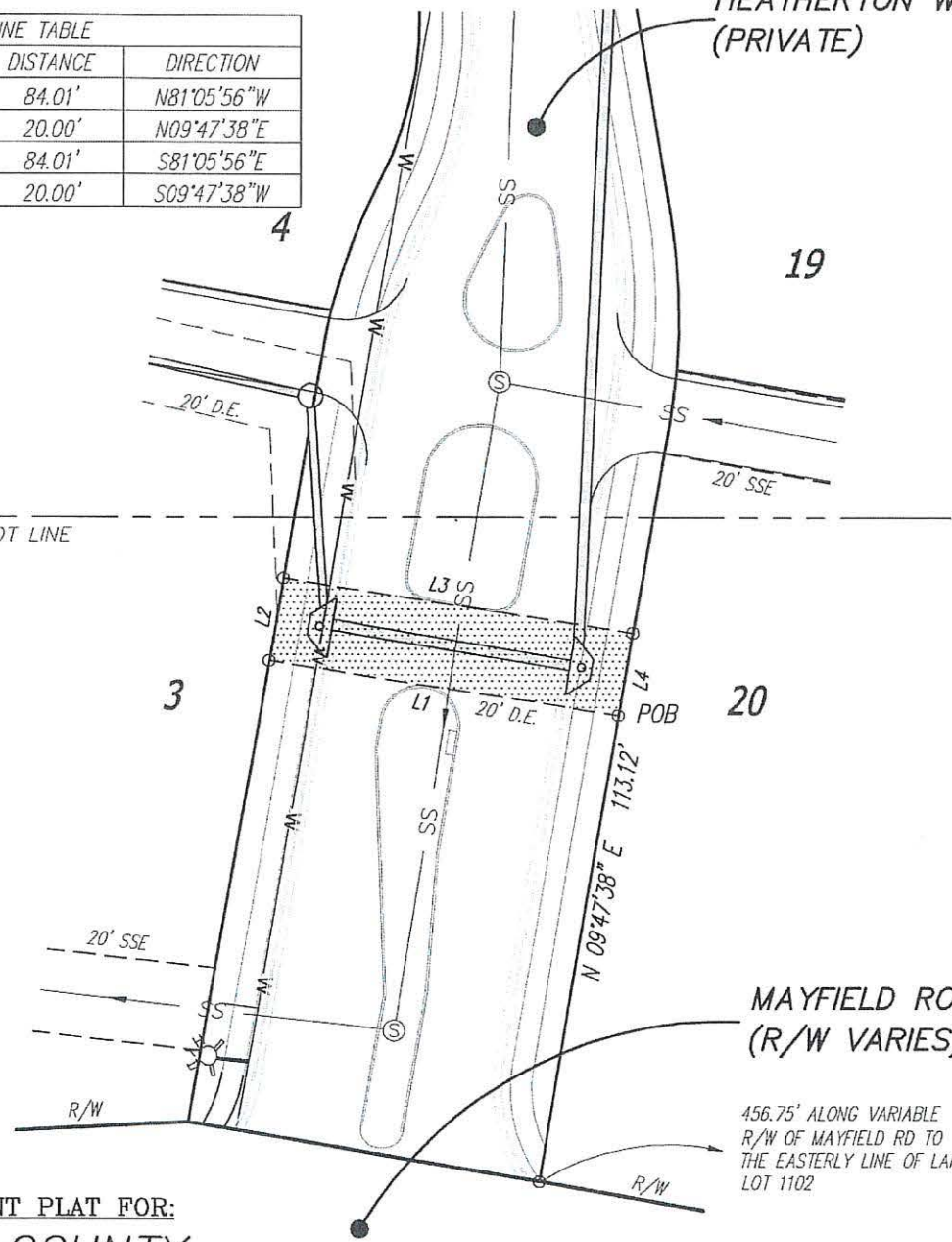

WATERLINE ENCROACHMENT PLAT FOR:
FULTON COUNTY
 HEATHERTON SUBDIVISION
 LOCATED IN LAND LOT 1102
 IN THE 2ND DISTRICT, 2ND SECTION
 IN THE CITY OF MILTON
 FULTON COUNTY, GEORGIA
 SCALE: 1" = 40' DATE: JULY 29, 2023

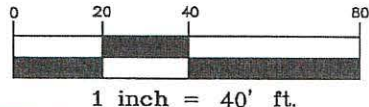

centerline

Surveying and Land Planning, Inc.
 1301 SHILOH ROAD, SUITE 1210, KENNESAW, GA. 30144
 PHONE: (770) 424-0028 FAX: (770) 424-2399

LSF#001298

ESMT ENCROACHMENT

EASEMENT ENCHROACHMENT AREA:

0.024 ACRES

1,029 SQ.FT.

LINE TABLE		
LINE	DISTANCE	DIRECTION
L1	42.89'	N67°37'12"W
L2	8.65'	N82°59'29"W
L3	20.00'	N07°00'31"E
L4	11.35'	S82°59'29"E
L5	40.08'	S67°37'12"E
L6	20.74'	S06°59'56"W

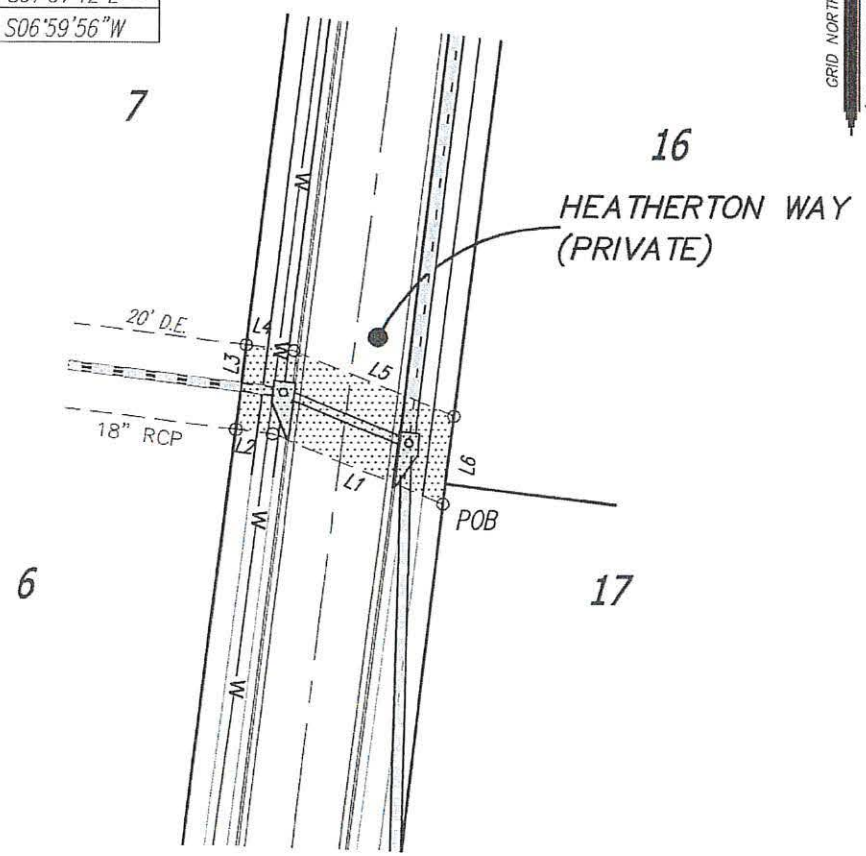
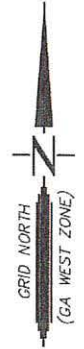

**WATERLINE
ENCROACHMENT PLAT FOR:**

FULTON COUNTY

HEATHERTON SUBDIVISION
LOCATED IN LAND LOT 1059
IN THE 2ND DISTRICT, 2ND SECTION
IN THE CITY OF MILTON
FULTON COUNTY, GEORGIA
SCALE: 1" = 40' DATE: JULY 29, 2023

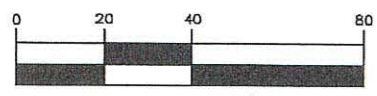

1 inch = 40' ft.



centerline

Surveying and Land Planning, Inc.

1301 SHILOH ROAD, SUITE 1210, KENNESAW, GA. 30144
PHONE: (770) 424-0028 FAX: (770) 424-2399

LSF#001298

ESMT ENCROACHMENT

EASEMENT ENCHROACHMENT AREA:

0.026 ACRES

1,029 SQ.FT.

LINE TABLE		
LINE	DISTANCE	DIRECTION
L1	12.94'	N82°41'49"W
L2	35.55'	N50°29'18"W
L3	7.09'	N82°56'53"W
L4	20.00'	N06°59'56"E
L5	12.91'	S82°56'53"E
L6	35.60'	S50°29'18"E
L7	7.06'	S82°41'49"E
L8	20.00'	S06°59'56"W

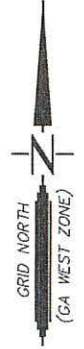

HEATHERTON WAY
(PRIVATE)

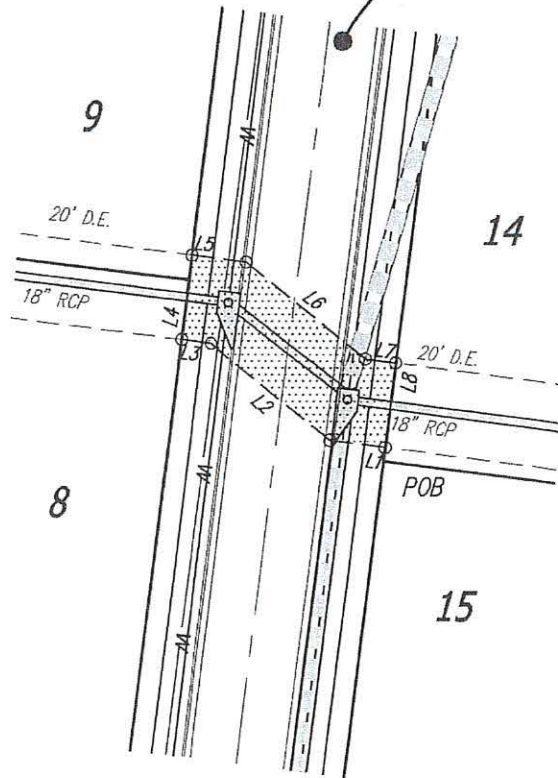

**WATERLINE
ENCROACHMENT PLAT FOR:
FULTON COUNTY**

HEATHERTON SUBDIVISION
LOCATED IN LAND LOT 1059
IN THE 2ND DISTRICT, 2ND SECTION
IN THE CITY OF MILTON
FULTON COUNTY, GEORGIA
SCALE: 1" = 40' DATE: JULY 29, 2023

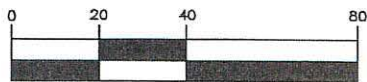

1 inch = 40' ft.



centerline

Surveying and Land Planning, Inc.

1301 SHILOH ROAD, SUITE 1210, KENNESAW, GA. 30144

PHONE: (770) 424-0028 FAX: (770) 424-2399

LSF#001298

ESMT ENCROACHMENT

EASEMENT ENCHROACHMENT AREA:

0.048 ACRES

2,093 SQ.FT.

CURVE TABLE				
CURVE	RADIUS	LENGTH	CHORD	BEARING
C1	60.00'	22.72'	22.59'	N15°32'32"E
C2	60.00'	20.35'	20.26'	S47°06'32"E

LINE TABLE		
LINE	DISTANCE	DIRECTION
L1	11.80'	S33°45'20"W
L2	103.22'	S77°51'22"W
L3	84.63'	N77°51'22"E
L4	6.91'	N33°45'20"E

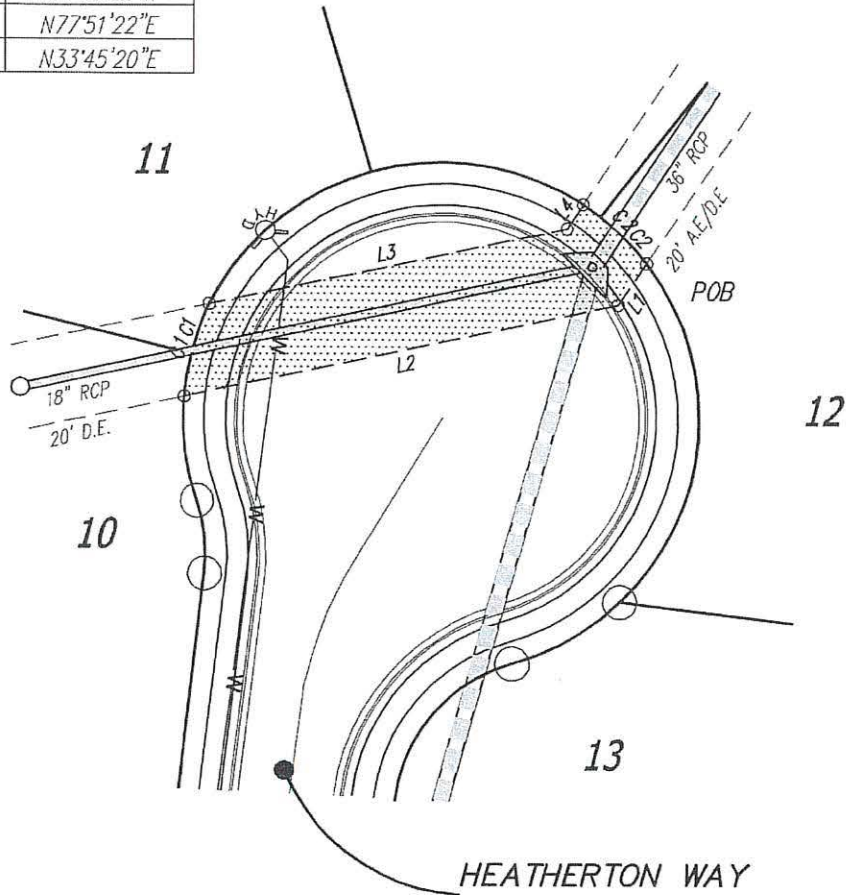

**WATERLINE
ENCROACHMENT PLAT FOR:**

FULTON COUNTY

HEATHERTON SUBDIVISION
 LOCATED IN LAND LOT 1059
 IN THE 2ND DISTRICT, 2ND SECTION
 IN THE CITY OF MILTON
 FULTON COUNTY, GEORGIA
 SCALE: 1" = 40' DATE: JULY 29, 2023

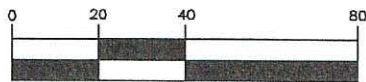

1 inch = 40' ft.



HEATHERTON WAY
(PRIVATE)

centerline

Surveying and Land Planning, Inc.

1801 SHILOH ROAD, SUITE 1210, KENNESAW, GA. 30144
 PHONE: (770) 424-0028 FAX: (770) 424-2399

LSF#001298

ESMT ENCROACHMENT